

16 15 14 13 12 11 10 9 8 7 6 5 4

M
L
K
J
H
G
F
E
D
C
B
A

ITEM NO.	PART NUMBER	DESCRIPTION	QTY.
1		Table Top	1
2	6109K724	27 mm Wide x 1500 mm Long Guide Rail for 54 mm Extra-Wide Sleeve Bearing Carriage	4
3	6109K724	27 mm Wide x 1500 mm Long Guide Rail for 54 mm Extra-Wide Sleeve Bearing Carriage	4
4	6109K227	Extra-Wide Sleeve Bearing Carriage	8
5	Profile Block - Fan Wheel	Profile Block	4
6	4885T41	Standard Duty Workbench Leg	2
7	L KEY - Fan Wheel	Key	4

NOTES:
1. ALL THE VARIOUS TABLE COMPONENTS ARE TO BE ASSEMBLED USING THE PROVIDED FASTENERS WITH THE

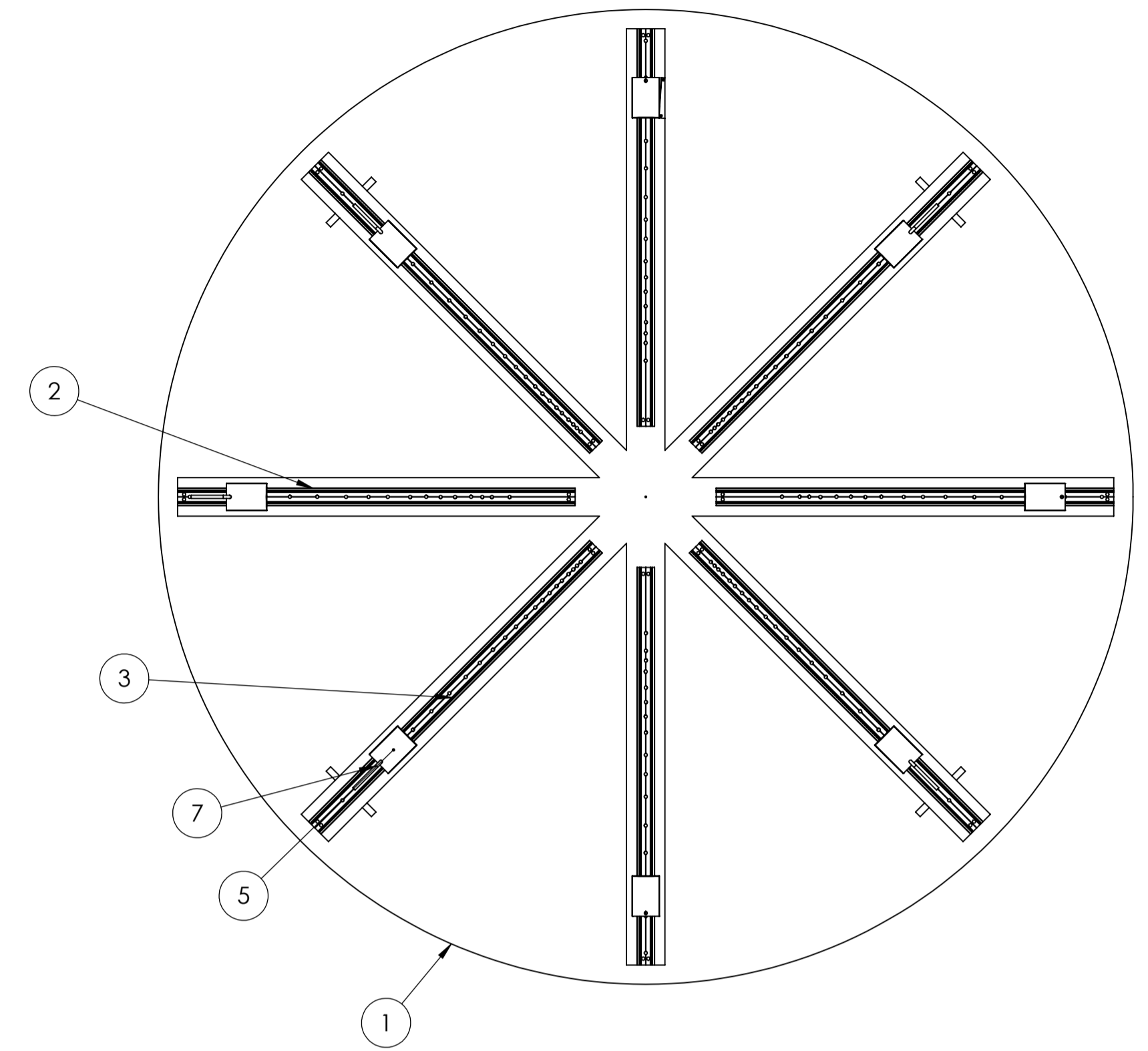

TOP VIEW

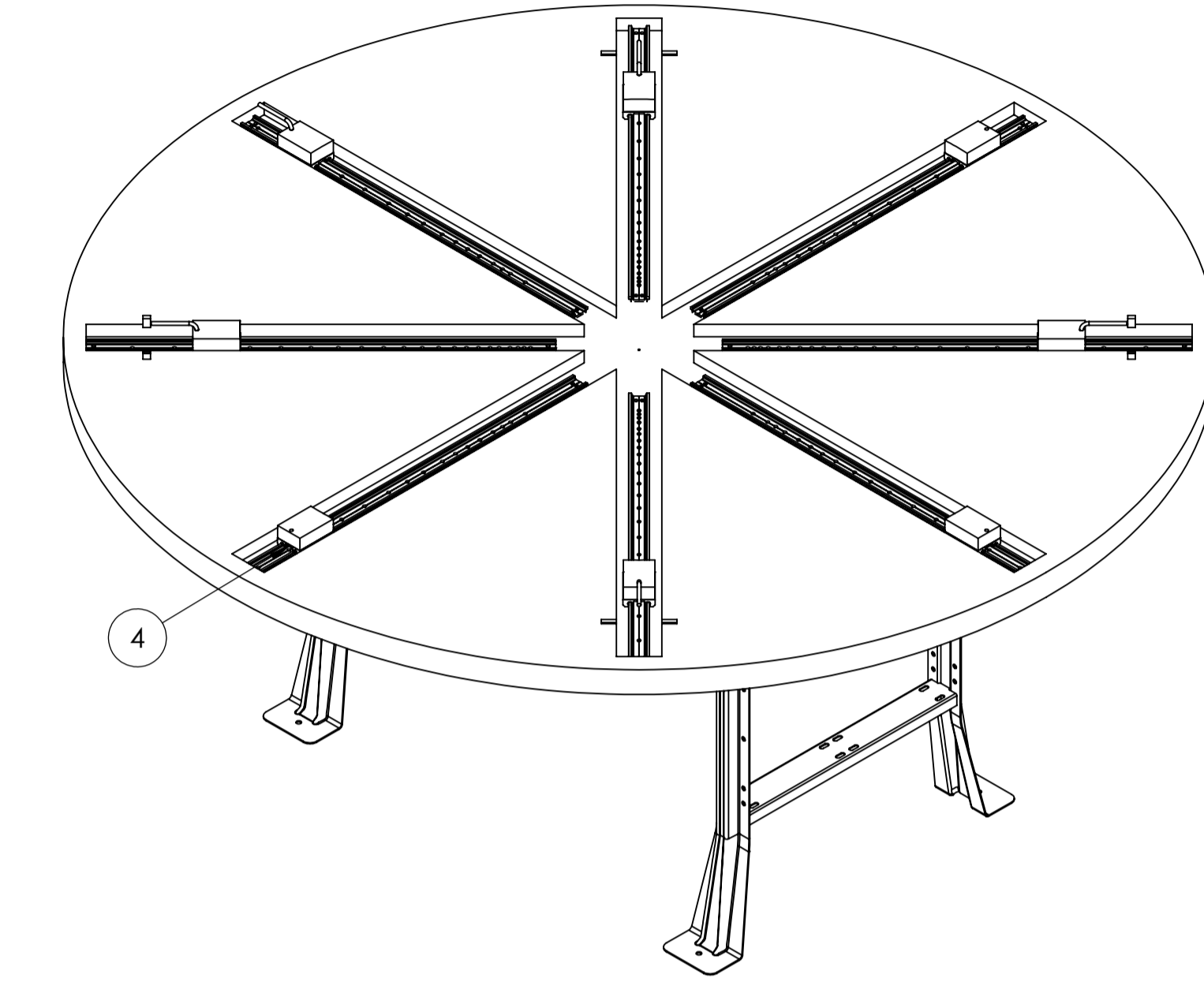

ISOMETRIC VIEW

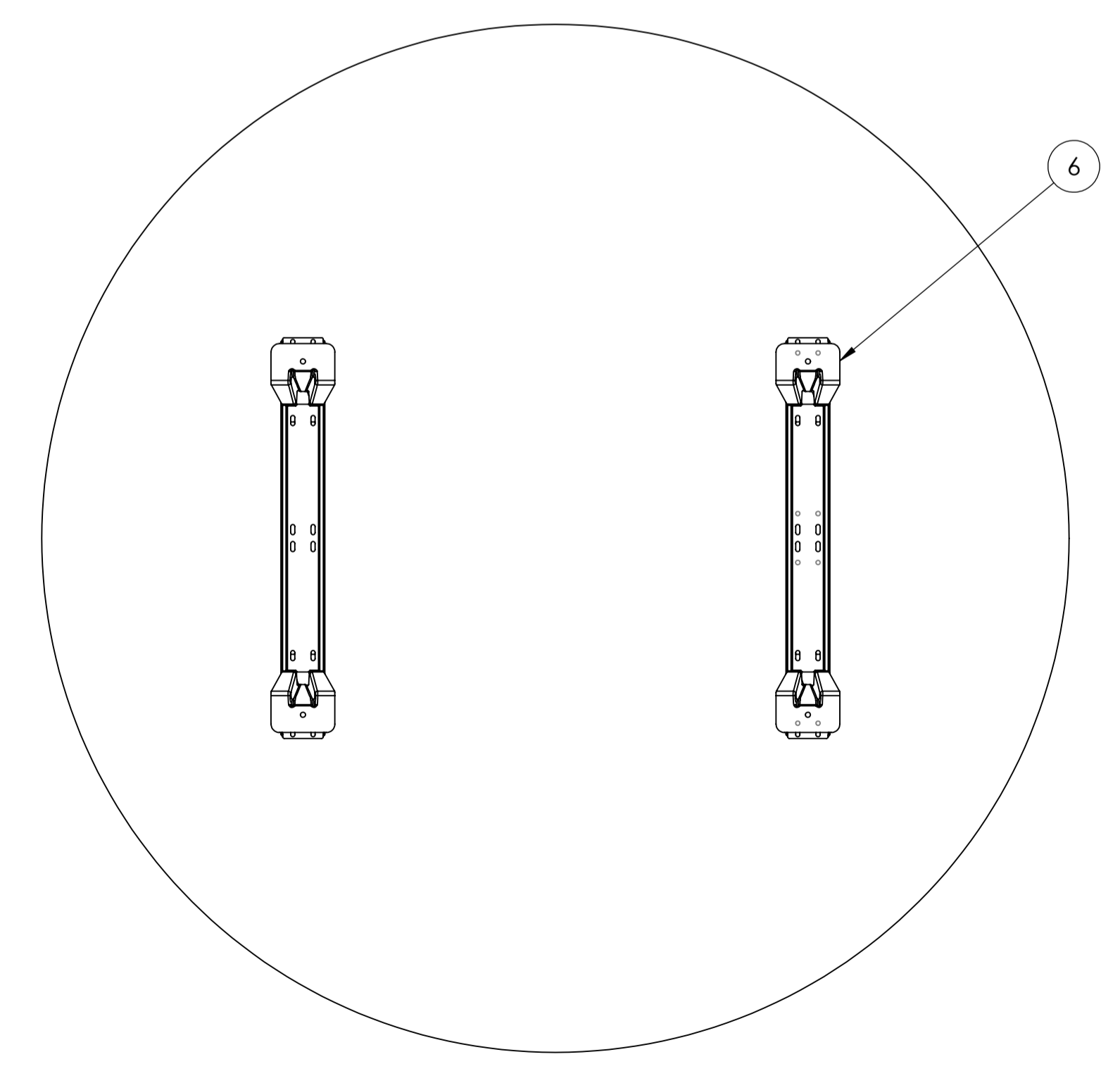

BOTTOM VIEW

UNLESS OTHERWISE SPECIFIED: DIMENSIONS ARE IN MILLIMETERS		FINISH:	DEBURR AND BREAK SHARP EDGES	DO NOT SCALE DRAWING	REVISION
SURFACE FINISH:					
TOLERANCES:					
LINEAR:					
ANGULAR:					
NAME	SIGNATURE	DATE	TITLE:		
DRAWN					
CHEK					
APPVD					
MFG					
Q.A.					
MATERIAL:		DWG NO.		Table Assembly Final	
WEIGHT:		SCALE:1:10		SHEET 1 OF 1	

11 10 9 8 7 6 5 4